

# SI POOL CONTROLLER — CONTROL CIRCUIT

ESP32R4 V1.2 — onboard PSU, 4x relays, I/O wiring · IEC 60617 symbols

2.4 GHz  
U.FL — see Note 10

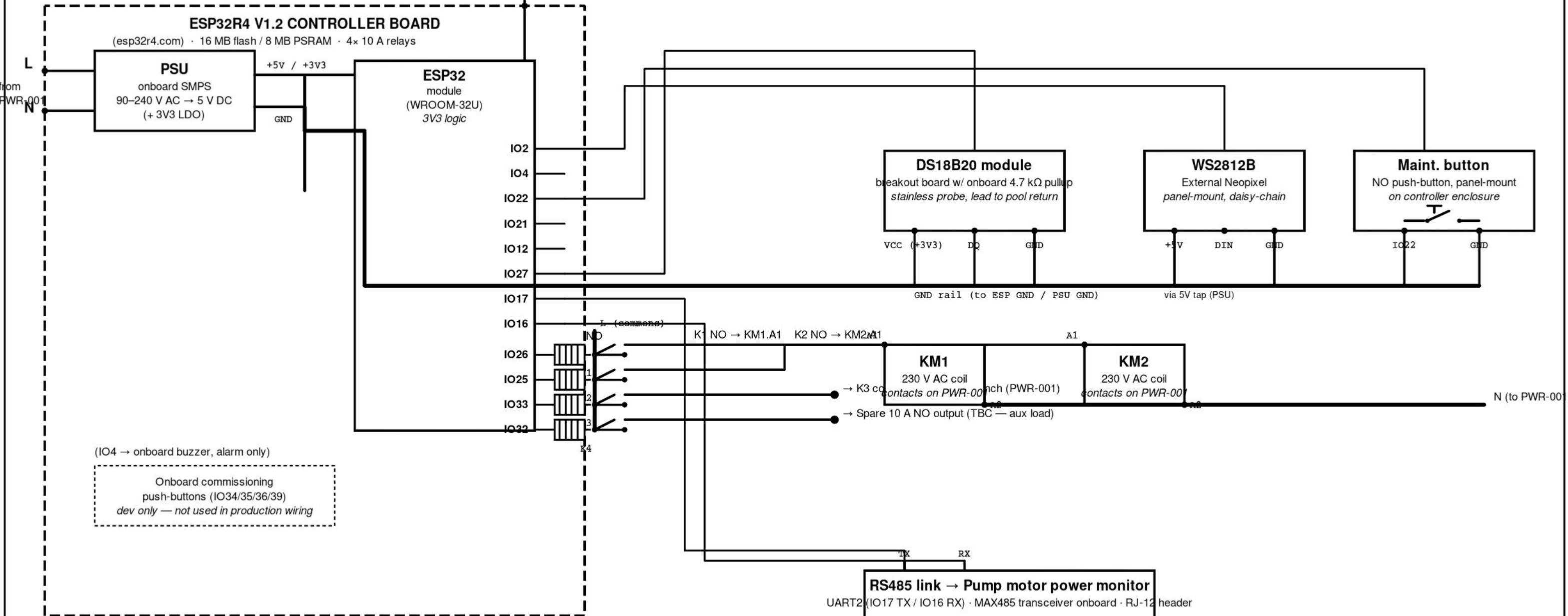

(IO4 → onboard buzzer, alarm only)

Onboard commissioning push-buttons (IO34/35/36/39) dev only — not used in production wiring

## COMPONENT SCHEDULE

U1	ESP32R4 V1.2 board (esp32r4.com)	onboard PSU + 4 relays + RS485
K1	Songle SRD-05VDC-SL-C, 10 A 250 V AC, IO26	drives KM1 coil
K2	Songle SRD-05VDC-SL-C, 10 A 250 V AC, IO25	drives KM2 coil
K3	Songle SRD-05VDC-SL-C, 10 A 250 V AC, IO33	switches pool light (PWR-001)
K4	Songle SRD-05VDC-SL-C, 10 A 250 V AC, IO32	spare aux output (TBC)
TP1	DS18B20 breakout module + stainless probe	on IO27, onboard 4.7 kΩ pullup
LD1	WS2812B external panel Neopixel	on IO2, daisy from onboard LED
SB1	Panel-mount NO push-button, momentary	on I2C hdr pin 4 = IO22 / SCL
RS1	MAX485 RS485 transceiver (this rev) → pump	UART2: IO17 TX / IO16 RX, Modbus RTU
KM1	Pump-contactor coil, 230 V AC (A1, A2)	contactor on PWR-001
KM2	Heat-pump-contactor coil, 230 V AC (A1, A2)	contactor on PWR-001
ANT1	External 2.4 GHz antenna, U.FL/IPEX pigtail (TBC by mfr)	required for production build

## NOTES

- Board mains tapped from PWR-001 L/N bus (fused spur) to pool pump motor's RS485 port (Modbus RTU, TBC)
- Relay commons → L; NO terminals → KM1.A1, KM2.A1, K3 (PWR-001), K4 spare. Contactor coils A2 → N.
- K3 NO contact is shown on PWR-001 (light branch); coil drive (IO33) is on this sheet.
- DS18B20 breakout on IO27 — onboard pullup, no external R.
- Maint. button on IO22 / SCL (I2C bus reserved); internal pull-up enabled in firmware.
- WS2812B (external) daisy-chains from onboard LED on IO2.
- Onboard IO34/35/36/39 + IO4 (buzzer) — dev / commissioning.
- RS485 = MAX485 transceiver (this rev). Future revisions integrate the transceiver — pin map unchanged.
- MOUNTING — moulded / 3D-printed base inside IP-rated enclosure. DS18B20 exits via cable gland to pool return; button + LED panel-mount on enclosure cover.
- 2.4 GHz ANTENNA — board has U.FL / IPEX connector for an external antenna. PRODUCTION must specify antenna PN + gain, pigtail length, and bulkhead-mount location.
- ENCLOSURE IP — min IP65 (damp / chlorine / splash). Outdoor: specify IP66 or higher. Glands + gaskets + panel-mount components must all match the selected IP rating.

CLIENT <b>RiddsAqua</b>		PROJECT <b>SI Pool Controller Board</b>	
DRAWING TITLE <b>Control Circuit Schematic</b>			
DRAWING No. <b>SI-POOL / CTRL-001C</b>	REV <b>— draft</b>	DATE <b>2026-05-21</b>	SHEET <b>2 of 2</b>
DRAWN BY <b>M. Trollip</b>	CHECKED <b>—</b>	APPROVED <b>—</b>	SCALE <b>NTS</b>